

ONLY
GLASS

MEDIAFACADE

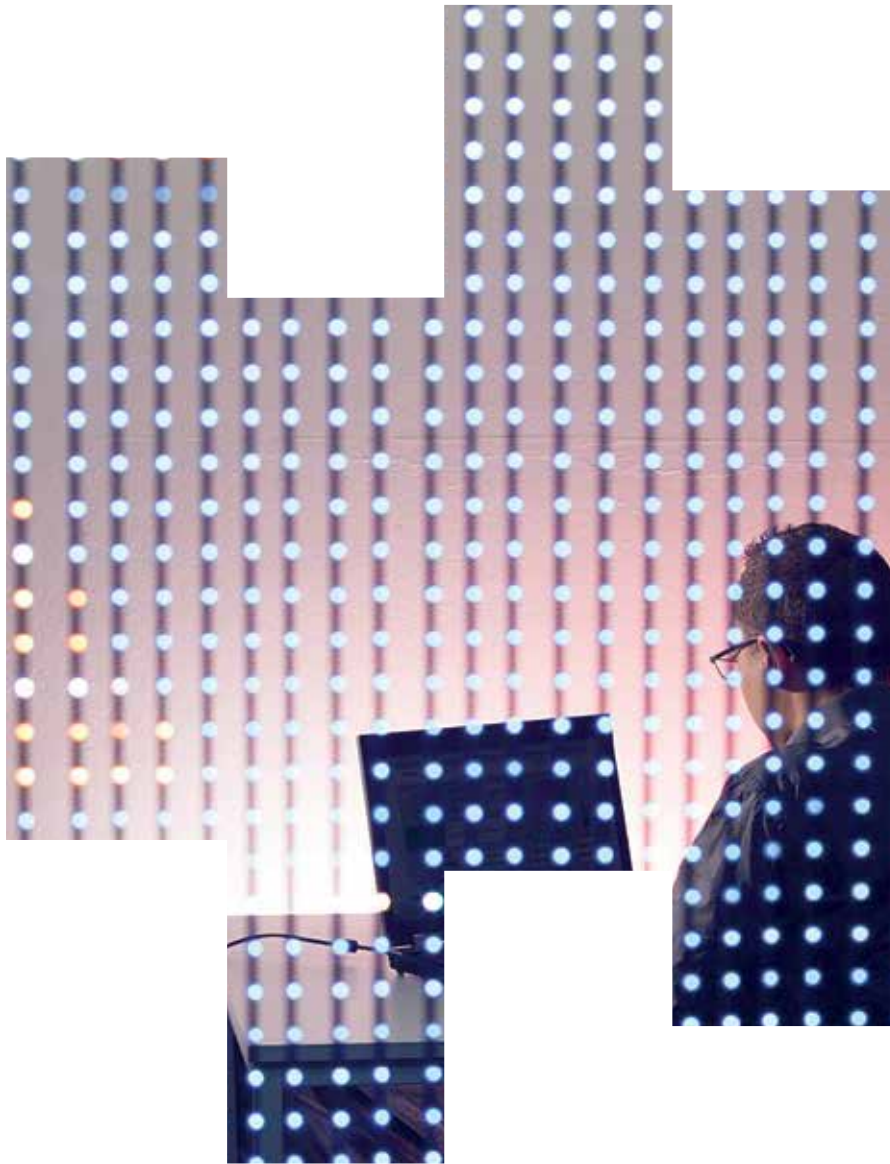

PARAMETERS OF MEDIA FACADES

TRANSPARENCY IN MOTION

ONLYGLASS.DE

PARAMETERS OF MEDIA FACADES



For the correct choice of media façade the investor and also the tendering planning engineer should be fully aware of its specific purpose. Possible usage and effect of a media façade depends on many things, mainly mutually influential parameters, the most important of which we shall subsequently discuss in brief.

TRANSPARENCY

The transparency of a media façade primarily depends on the pixel pitch of the LEDs and the width of used carrier plates, which might be cables, printed boards or bars. As the pixel pitch increases the transparency increases as well and vice versa. But even media façades with a similar pixel pitch still have significant differences. For example, solutions available on the market today offering a 40 mm pixel pitch have transparency rates between 60% and 95%. Generally, integrated displays offer higher transparency, as no additional supporting constructional elements are necessary. The argument that LED screens in front of a façade, which have low transparency offer additional sun protection can only be interpreted as an excuse due to missing key characteristics. The additional »sun protection argument« is in contradiction with the known fact of an increased risk of thermal breakage on the glass façade behind the LED screen.

NUMBER OF PIXELS

The image quality primarily depends on the number of pixels, which define the resolution of the image. The resolution is independent of the surface area of the LED screen and the viewing distance. For example it is simply impossible to display a stickman with only five pixels. This shows that a certain number of pixels are required to display a clear image on the LED screen. For simple colour visualisations a few thousand pixels may be sufficient, whereas for cartoons and single elements, such as one butterfly (complexity of the image is low) it takes 10.000 – 20.000 pixels. For the display of pictures and videos with detailed elements, such as a flower bed it takes a minimum of 60.000 to 80.000 pixels to achieve a high resolution image quality.

IMAGE FORMAT/WIDTH-TO-HEIGHT RATIO

The decision regarding formats of a media façade often depends on the available surface area or aesthetic aspects in order to fit in well with the design of the building. However, it is important to keep in mind that most images, videos have a standard format of 4:3 respectively 16:9. Therefore, if the media façade does not meet these format requirements a certain area of the media façade will remain unused unless images and videos are customized to fit the screen format.

VIEWING DISTANCE AND INSTALLATION HEIGHT

LEDs usually have an angle of radiation of 120°. Installing the LED screen vertically into a façade means a dead angle of 30°. Therefore with increasing installation height of the media façade the viewing distance increases as well in order to view the entire surface area of the display. The graphic below illustrates the interplay between viewing distance and installation height.

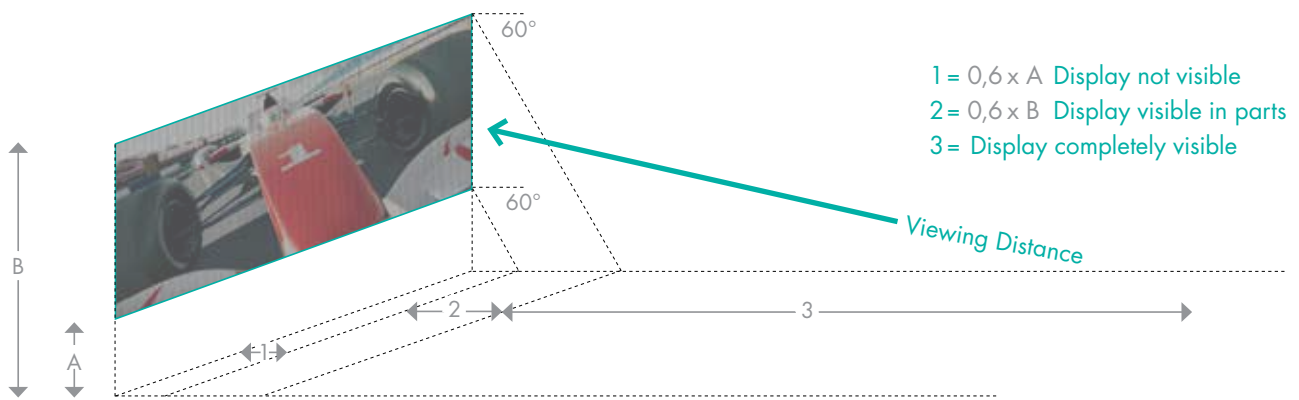

Picture: Minimal Viewing Distance

The rule of thumb to view a complete image is:

> 1 mm PIXEL PITCH EQUALS 1 m VIEWING DISTANCE

If the viewing distance to the LED screen is too low single pixels instead of a complete image become visible. This effect is similar to the headlights of a car that is approaching you at night. Looking at the headlights from far away the eye notices one single light. However, the closer the headlights of the car get the easier it becomes for the eye to notice two separate headlights. The same effect occurs if the actual viewing distance is below the minimum viewing distance.

BRIGHTNESS

The brightness of the LED screen and its surrounding environment determine the configuration of the media façade. The following data can be used as reference values for central Europe:

- At twilight and night 1.000–1.500 nits (cd/m²)
- At daylight 2.500–3.000 nits (cd/m²)
- At direct sunlight 6.000 nits (cd/m²)

Naturally, the reference values for daylight and direct sunlight are of course higher in southern countries. Also special coatings (i.e. solar glass with lower light transmission) on the outer glass pane of the IGU may increase the requirements regarding brightness.

For example, a media façade with LEDs that emit 2.5 cd and that have a pixel pitch of 50 mm has in total 400 LEDs/m². This is equal to 1.000 nits. A media façade with such parameters would have limited visibility at daylight. However, this example illustrates the importance of the pixel pitch regarding suitability at daylight.

Also it becomes clear that there is a high level of interdependence between all parameters, i.e. brightness and viewing distance impact pixel pitch and vice versa. In case of doubt the lower pixel pitch should be selected even if this generally leads to greater investment costs.

Consequently it can be exactly pinpointed in advance as to which direction and at which operating times the media façade should be used. These parameters should be calculated by a specialist if possible because there is no possibility of an upgrade later on.

TEMPERATURE INFLUENCE

A significant influencing factor regarding lifetime of a LED is the surrounding temperature. In general it can be said that with increasing temperature the lifetime of the LED decreases. However, the price of a LED also depends on the warranty given by the LED manufacturer based on the temperature requirements. Low priced LEDs may only function properly between a temperature between $+5^{\circ}\text{C}$ and $+60^{\circ}\text{C}$. This temperature range is not sufficient for a media façade in central Europe, which is exposed to high temperatures. A LED with a minimum temperature range between -20°C to $+100^{\circ}\text{C}$ would be recommended.

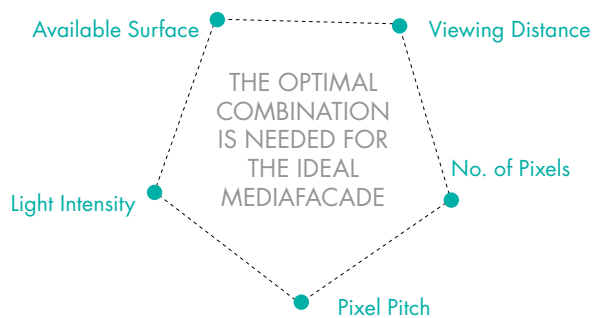

Picture: The magical Polygon

DEPENDENCY ON PARAMETERS

For a media façade with a predetermined size and an intended high resolution solution, the brightness and minimum viewing distance are predetermined by technology. In case

the brightness is predetermined and a specific brightness is required, this is only possible through size adjustment or by increasing the pixel distance.

Depending on the area in which the media façade is to be used, a sequence of priorities of the most required and decisive parameters should be determined, in order to achieve the best possible results for planned use. Consequently, it is exceptionally important that the requirements of media façades or their future functionality are accurately anticipated and planned in advance.

SUMMARY

In conclusion, it is not as straightforward to find the ideal setup of all parameters. Depending on the planned usage of the media façade at least a sequence of priorities is needed. Therefore it is quite important that the requirements of the media façade are precisely determined in advance.

The key points to be defined are:

- content (i.e. color visualization, text, pictures, videos) to find the right resolution
- time of day in use and geographic direction to specify the needed brightness
- size and dimension of the required screen
- viewing distance to define the maximum pixel pitch

Keeping these characteristics in mind and precisely defining them in the tender process will make it much more likely to meet the investors' expectations.